

The Elan Factory – Product Data Sheet



High torque, pre-engaged starter motor

The Elan Factory has engineered a high torque starter motor as a direct replacement for the Lucas M35G OEM starter. This compact starter motor may be installed in exactly the same position but offers significantly more room around various components such as the engine, gearbox, chassis and bodywork. The adapter plate has a custom machined profile to ensure the correct clearance when installed on a small Ford cylinder block, such as 120E, 701M, 711M etc.



Since the introduction of reduction gear starters many years ago, they are now standard equipment on modern road going and race cars. The reliability and performance of these items has been significantly improved through the use of high quality components. This type of starter motor utilises sealed ball races to support the driven components such as the internal driven gear and pinion. This means the rotating critical components are mainly unaffected by extremes of temperature, unlike the standard Lucas unit. A significant reduction in cranking current is achieved through the use of a reduction gearbox. In turn, this reduction in current assists in providing a greater spark plug voltage when starting the engine.

This versatile starter motor incorporates a reduction gearbox as well as a pre-engaged pinion mechanism. This configuration delivers maximum torque at all cranking speeds whilst the pre-engaged pinion mechanism ensures correct starter ring gear engagement (thus minimising pinion and ring gear wear).

Installation in confined spaces is made easy as the starter motor offers flexibility of orientation. This is achieved by incorporating a vernier adjustable mounting plate. This plate is manufactured using CNC facilities and offers angular adjustment in 20 degree increments for a full 360 degrees. Less expensive starter motors are often compromised by limited angular adjustment.

Some high torque starter motors are poorly designed and are prone to premature failure when installed on a high capacity, high compression engine. This is because two generic 6mm screws are expected to provide sufficient clamping pressure for the adaptor plate, and cope with high starting torque forces in the shear plane. The Elan Factory has overcome this design problem by incorporating two internal locating dowels that manage the high starting torque forces.

The Elan Factory – Product Data Sheet



High torque, pre-engaged starter motor



Photograph depicts adapter plate bolted to fixture prior to machining



Photograph depicts the adapter plate being machined with counter bored holes

- Stator motor overall length – 195.0mm (7.670 inches)
- Maximum overall height – 130.0mm (5.11 inches)
- Body rotation/swing distance – 100mm (3.93 inches)
- CNC machined gearbox casting – Aluminium alloy AA610 (heat treated to T6 specification)
- CNC machined vernier adapter plate – Aluminium alloy AA610 (heat treated to T6 specification)
- Main body material – Aluminium alloy
- Pinion – 9 tooth
- Weight – 4.0Kgs
- Warranty – Two years

This starter motor is supplied fully assembled and offers greater flexibility in installation and reliability when compared with the original equipment. It is also interesting to note there is significant weight saving over the OEM and other replacement starter motors. Standard Lucas unit weight – 4.5Kgs and Bosch replacement unit weight – 5.8Kgs

Installation checks

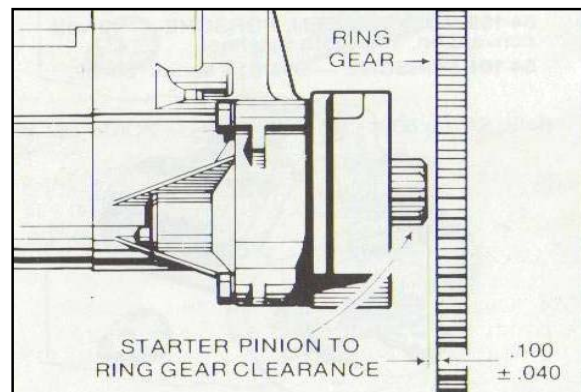
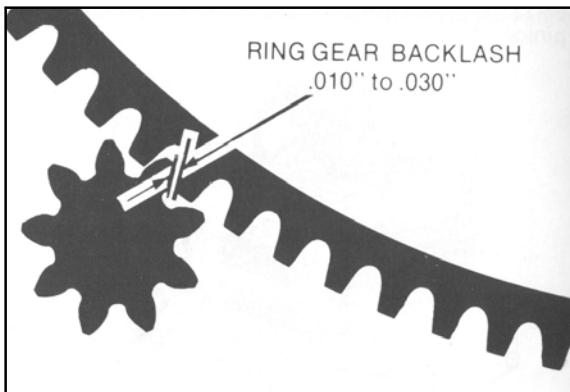

For further information regarding starter motor components, please phone The Elan Factory on (613) 9761-1903 or fax on (613) 9739-8944. Alternatively you can write to The Elan Factory at 5 Marong Court, Boronia Heights 3155, Melbourne, Australia
email = sales@elanfactory.com.au website = www.elanfactory.com.au

6 August 2006